



Markar Countersink Process Change

ASSA ABLOY

Markar Architectural Products, Inc. a subsidiary of Adams Rite Manufacturing Co.
260 Santa Fe Street, Pomona, CA 91767 Phone: 800-872-3267 909-632-2300 Fax: 800-232-6752

www.markar.com

As a part of our continuing manufacturing process improvements, Markar is changing the method used in the way we countersink the mounting holes on Markar 300 series hinges. The new punch and coining process will insure accurate, repeatable quality through each hinge by providing a consistent depth and diameter to all mounting holes.

With this change, the appearance of the templated holes will change slightly. The hinges manufactured using the new process will feature holes with "internal teeth" appearance. There will be no other physical changes to the hinge as a result of this process change, and this will in no way affect the performance or durability of the product.

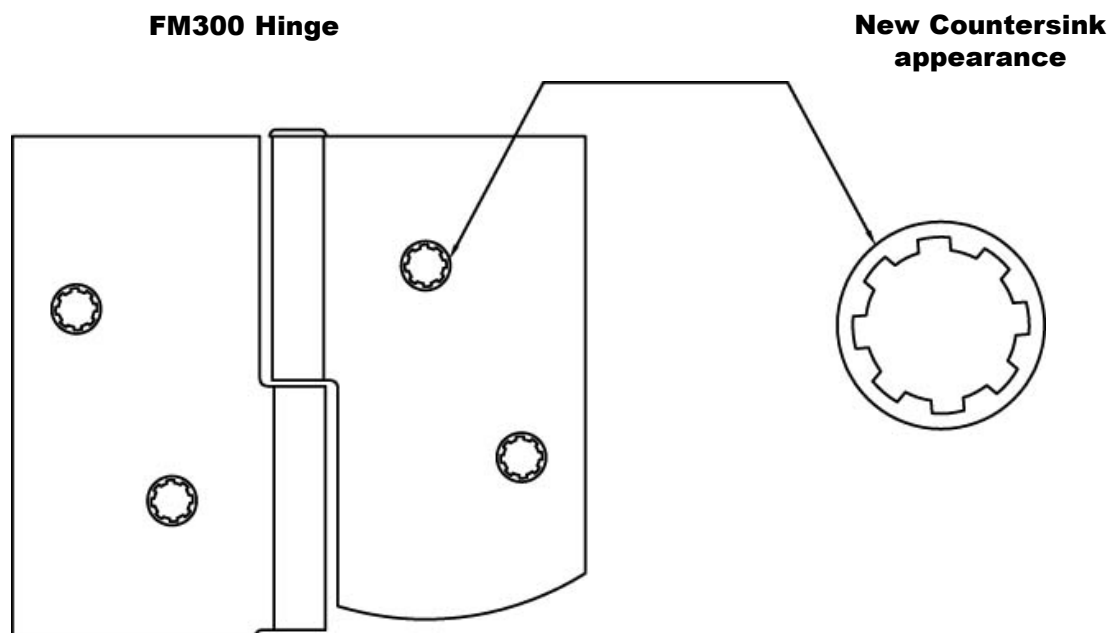

Implementation of this change is currently under way. The Markar FM300 series hinges will be the first to be manufactured using this new process. These hinges are expected to start shipping in August 2009. In the months following, other Markar hinges will be produced using this new method as well.

If you have any questions regarding this manufacturing change please contact our Customer Satisfaction or Technical Support groups at **800 872-3267**.

Additional information can also be obtained from our website at www.markar.com.