



## NEW - Markar Wide Throw Hinge Options

**ASSA ABLOY**

**Markar Architectural Products, Inc.** a subsidiary of Adams Rite Manufacturing Co.  
 260 Santa Fe Street, Pomona, CA 91767 Phone: 800-872-3267 909-632-2300 Fax: 800-232-6752

[www.markar.com](http://www.markar.com)

The Markar® Stainless Steel Wide Throw hinges provide an excellent solution in applications where additional clearance is required between the frame/wall and the door when opened 180 degrees. This is typically needed to clear custom brick moldings, and special door and frame designs.

In order to provide an array of standard size configurations, Markar® has designed an ordering matrix that encompasses the most commonly requested sizes. Creating this range of standard configurations will help in expediting the ordering process and reduce lead times for our valued customers.

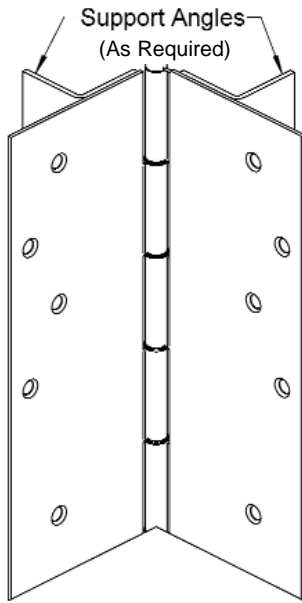

FM300 Wide throws that are above 2" clearance require support angles.

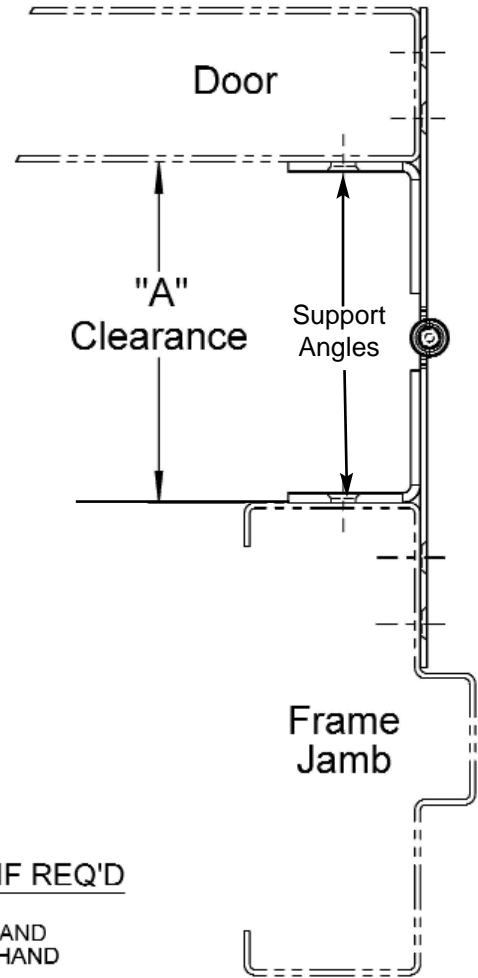

**FM300WT - XX - XX - XX**

FULL MORTISE WIDE THROW

\* HANDING IF REQ'D

LH LEFT HAND  
 RH RIGHT HAND

"A" CLEARANCE

LENGTH

1 3/4" - 2"	10
2 1/16" - 2 1/2"	20
2 9/16" - 3 3/16"	30
3 1/4" - 3 7/8"	40
3 15/16" - 4 9/16"	50

01	7'-0
02	8'-0
03	10'-0
04	6'-8" *
05	7'-2" *

\* HANDING IS REQUIRED FOR CUT DOWNS AND MODIFICATIONS

If you have any questions regarding this manufacturing change please contact our Customer Satisfaction or Technical Support groups at **800 872-3267**.

Additional information can also be obtained from our website at [www.markar.com](http://www.markar.com).